

MARKAGE FD

Rectangular fire damper for installation in the wall of the fire compartment



CE
0749



Table of content

Declaration of performance	3
Product presentation MARKAGE FD	4
Range and dimensions MARKAGE FD	5
Variant MARKAGE FD + BP FM	5
Range and dimensions MARKAGE FD + BP FM	5
Evolution - kits	6
Options - at the time of order	7
Flange types - at the time of order	7
Storage and handling	8
Installation	8
Installation in rigid wall, sealing with mortar	9
Installation in rigid wall, sealing with rigid rock wool boards with coating	10
Installation in flexible wall, sealing with rigid rock wool boards with coating	12
Installation with vertical suspension (VS MAS)	14
Operation and mechanisms	16
Electrical connection	19
Weights	20
Selection data	22
Sample order	23
Approvals and certificates	23

Explanation of the abbreviations and pictograms

Wn = nominal width	E.TELE = power supply magnet	Sn = free air passage
Hn = nominal height	E.ALIM = power supply motor	ζ [-] = pressure loss coefficient
Dn = nominal diameter	V = volt	Q = airflow
E = integrity	W = watt	ΔP = static pressure drop
I = thermal insulation	Auto = automatic	v = air speed in the duct
S = smoke leakage	Tele = remote controlled	Lwa = A-weighted sound power level
Pa = pascal	Pnom = nominal capacity	Lw oct = sound power level per octave midband
ve = vertical wall penetration	Pmax = maximum capacity	dB(A) = A-weighted decibel value
ho = horizontal floor penetration	GKB (type A) / GKF (type F): "GKB"	ΔL = correction factor
o -> i = meets the criteria from the outside (o) to the inside (i)	stands for standard plasterboards (type A according to EN 520) while "GKF"	
i <-> o = fire side not important	plasterboards offer a higher fire resistance for a similar plate thickness (type F according to EN 520)	
V AC = Volt alternating current	Cal-Sil = calcium silicate	
V DC = Volt direct current	OP = option (delivered with the product)	
	KIT = kit (delivered separately for repair or upgrade)	
	PG = connection flange to the duct	



large dimensions



fast and easy installation

DECLARATION OF PERFORMANCE

CE_DOP_Rf-t_C17_EN - A-07/2022

1. Unique identification code of the product-type:	MARKAGE FD		
2. Intended use/s:	Rectangular multi-blade fire damper to be used in conjunction with partitions to maintain fire compartments in heating, ventilating and air conditioning installations.		
3. Manufacturer:	Rf-Technologies NV, Lange Ambachtstraat 40, B-9860 Oosterzele		
4. System/s of AVCP:	System 1		
5. Harmonised standard / European Assessment Document: notified body / European Technical Assessment, Technical Assessment Body, notified body, certificate of constancy of performance:	EN 15650:2010, BCCA with identification number 0749; EN 15650:2010 BCCA-0749-CPR-BC1-606-0464-15650-XX-2517		
6. Declared performance according to EN 15650:2010	(Fire resistance according to EN 1366-2 and classifications according to EN 13501-3)		

Essential characteristics	Performance		
	Wall type	Wall	Sealing
Range			
200x200 mm ≤ MARKAGE FD ≤ 1000x2400 mm	Rigid wall	Aerated concrete ≥ 100 mm	Mortar
	Flexible wall	Metal studs/gypsum plasterboard Type F (EN 520) ≥ 100 mm	Stone wool + coating ≥ 140 kg/m ³ Stone wool + coating ≥ 140 kg/m ³
1	Type of installation: built-in 0/90/180/270°		

Essential characteristics	Performance		
	Installation	Classification	Harmonised standard
	1	EI 90 (V _{e,i} ↔ o) S (300Pa)	EN 15650:2010
	1	EI 90 (V _{e,i} ↔ o) S (300Pa)	
	1	EI 90 (V _{e,i} ↔ o) S (300Pa)	

Nominal activation conditions/sensitivity:
 Response delay (response time): closure time
 Operational reliability: cycling
 Durability of response delay:
 Durability of operational reliability:

The performance of the product identified above is in conformity with the set of declared performances/s. This declaration of performance is issued, in accordance with Regulation (EU) No 305/2011, under the sole responsibility of the manufacturer identified above.

Pass
 Pass
 BFL(T) - 10000 cycles; BFN(T) - 10000 cycles;
 BFT) - 10000 cycles
 Pass
 Pass

Signed for and on behalf of the manufacturer by:
Mathieu Steenland, Technical Manager

 Oosterzele, 07/2022



Product presentation MARKAGE FD

The rectangular fire damper MARKAGE FD is suitable for installation in the wall and has a fire resistance of 60 or 90 minutes. The damper is available in a wide number of sizes. Fire dampers are used to prevent the spread of fire and smoke through ventilation systems.

Fire dampers are installed where air ducts penetrate fire-resistant compartment walls. Their role is to restore the fire resistance grade of the penetrated wall and to prevent smoke propagation. Fire dampers are distinguished by their degree of fire resistance, by their aerodynamic properties as well as by their installation ease. Rf-Technologies' fire dampers are all CE marked. They can be equipped with various types of mechanisms depending on the specific needs linked to the project or to the local regulations.

- ☑ can be activated with a bus communication module
- ☑ large dimensions



- compliant with EN 15650
- tested according to EN 1366-2
- suitable for rigid wall and light wall (metal stud gypsum plasterboard wall)
- maintenance-free
- for indoor use

1. actuator compartment (+ communication module)
2. actuator
3. damper blade mechanism
4. damper blade
5. damper housing
6. access hatch

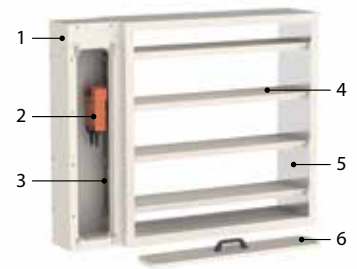

Range and dimensions MARKAGE FD

Rectangular fire damper for installation in the wall of the fire compartment.
 Hn in steps of 200 mm, Wn in steps of 50 mm. A = 295 mm.
 The dimensions do not include connection frames or grilles (PG30, PPT).

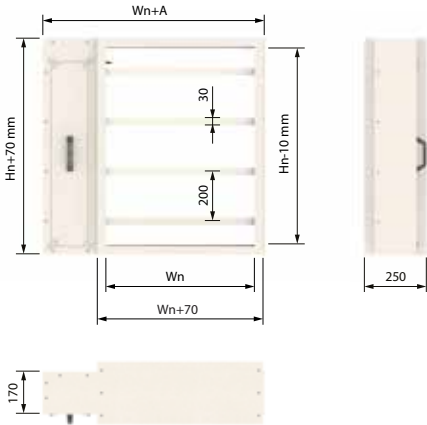

	IV	V
(W x H) mm	200x200	1000x2400





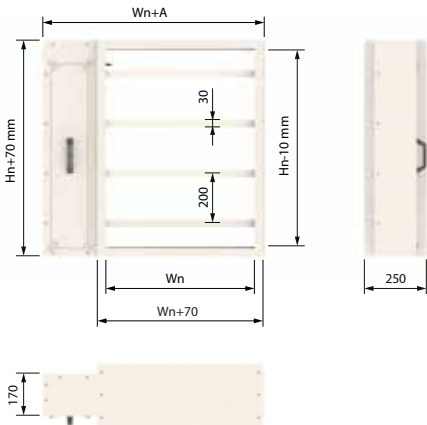



Variant MARKAGE FD + BP FM

Fire damper with provision for a bus communication module.
 A = 295 mm.
 The dimensions do not include connection frames or grilles (PG30, PPT).



	IV	V
(W x H) mm	200x600	1000x2400

Evolution - kits

	KITS BFLT24	Spring return actuator BFL 24V with thermo-electric fuse (T)
	KITS BFLT230	Spring return actuator BFL 230V with thermo-electric fuse (T)
	KITS BFLT24-ST	Spring return actuator BFL 24V with thermo-electric fuse (T) and plug (ST)
	KITS BFNT24	Spring return actuator BFN 24V with thermo-electric fuse (T)
	KITS BFNT230	Spring return actuator BFN 230V with thermo-electric fuse (T)
	KITS BFNT24-ST	Spring return actuator BFN 24V with thermo-electric fuse (T) and plug (ST)
	KITS BFT24	Spring return actuator BF 24V with thermo-electric fuse (T)
	KITS BFT230	Spring return actuator BF 230V with thermo-electric fuse (T)

**KITs BFT24-ST**

Spring return actuator BF 24V with thermo-electric fuse (T) and plug (ST)

**KITs BP FM**

Base plate for a bus communication module

VS

Mounting brackets for vertical suspension

Options - at the time of order**BP FM**

Base plate for a bus communication module

VS

Mounting brackets for vertical suspension

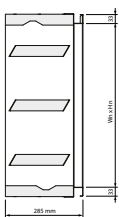
Flange types - at the time of order**PG30**

Flange for connection to metal ducts.

**PPT**

Galvanised steel grille.

Storage and handling

Storage and handling

As this product is a safety element, it should be stored and handled with care.

Avoid:

- any kind of impact or damage
- contact with water
- deformation of the casing

It is recommended:

- to unload in a dry area
- not to flip or roll the product to move it
- not to use the damper as a scaffold, working table, etc.
- not to store smaller dampers inside larger ones

Installation

General points

- The installation must comply with the installation manual and the classification report.
- Axis orientation: see the declaration of performance.
- Avoid obstruction of adjoining ducts.
- Product installation: always with closed damper blade.
- Verify if the blade can move freely.
- Please observe safety distances with respect to other construction elements. The operating mechanism must also remain accessible: allow for a clearance of 200 mm around the housing.
- The air tightness class will be maintained if the damper is installed according to the installation manual.
- Rf-t fire dampers are always tested in standardised constructions according to EN 1366-2. The achieved results are valid for similar supporting constructions with a fire resistance, thickness and density equal or superior to the supporting construction used during the test.
- The damper must remain accessible for inspection and maintenance.
- Schedule at least 2 visual checks each year.

	TEST	
2021	<input checked="" type="checkbox"/>	<input checked="" type="checkbox"/>
2022	<input checked="" type="checkbox"/>	<input type="checkbox"/>
2023	<input type="checkbox"/>	<input type="checkbox"/>
2024	<input type="checkbox"/>	<input type="checkbox"/>
2025	<input type="checkbox"/>	<input type="checkbox"/>

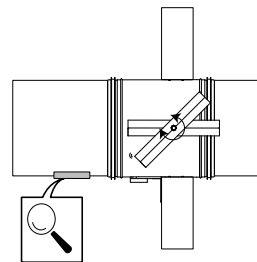

Installation in rigid wall, sealing with mortar

The product was tested and approved in:

Range	Wall type	Sealing	Classification
200x200 mm ≤ MARKAGE FD ≤ 1000x2400 mm	Rigid wall	Aerated concrete ≥ 100 mm	Mortar
			El 90 (v _e i ↔ o) S (300Pa)

1

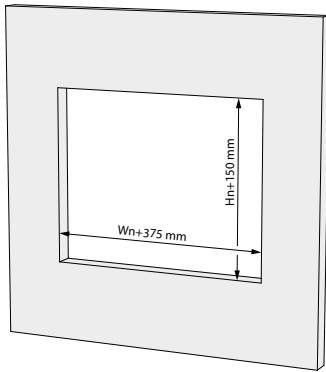

1. Make an opening with dimensions (Wn+375) x (Hn+150) mm.

2

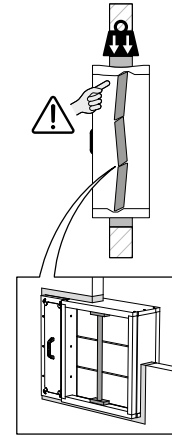

2. Mount the damper in the opening. Support the tunnel and block the damper blades in the closed position to prevent deformation of the tunnel while the sealing is curing.

3

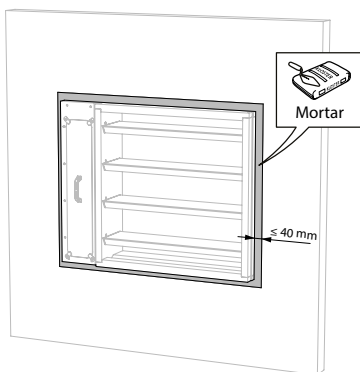

3. Seal the rest of the opening with standard mortar.

4

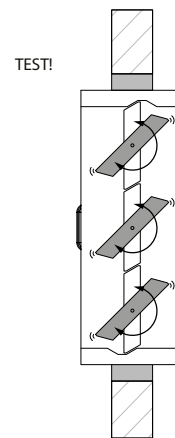

4. Check the functioning of the damper blades after the curing time of the sealing and after removing the struts. Test the mechanism of the damper.

Installation in a rigid wall, sealing with rigid rock wool boards with coating

The product was tested and approved in:

Range	Wall type	Sealing	Classification
$200 \times 200 \text{ mm} \leq \text{MARKAGE FD} \leq 1000 \times 2400 \text{ mm}$	Rigid wall	Stone wool + coating $\geq 140 \text{ kg/m}^3$	EI 90 (v_e i \leftrightarrow o) S (300Pa)

1

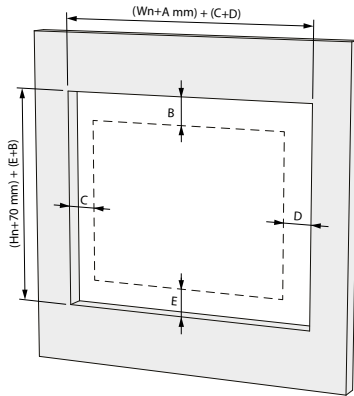

1. Make an opening with dimensions $(Wn+295+C+D) \times (Hn+70+B+E)$ mm.

2

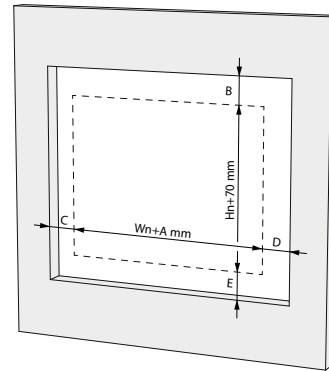

2. Mount the damper in the opening. Sealing B, C, D & E between 50 and 400 mm each.

The damper does not need to be centered in the opening. The maximum distance between the damper and the edge of the opening is 400 mm.

3

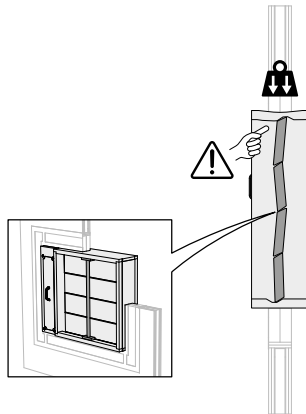

3. Support the tunnel and block the damper blades in the closed position to prevent deformation of the tunnel while the sealing is curing.

4

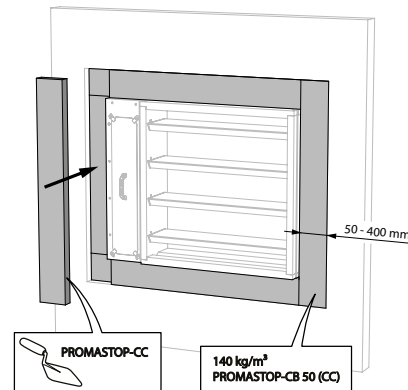

4. Seal the rest of the opening with 2 layers of 50 mm thick coated rigid mineral wool panels (type PROMASTOP CB-CC). The panels must be installed staggered. When installing, always apply coating (type PROMASTOP CC) to the end of each panel.

5

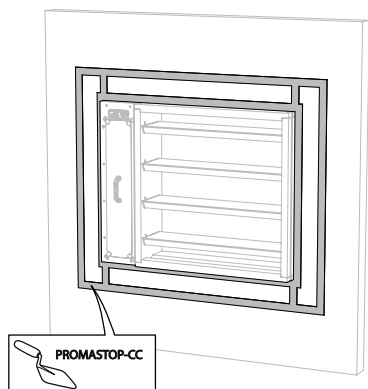

5. The panels must be installed staggered and the joints must be covered all around with coating (type PROMASTOP-CC) to create a uniform layer thickness for the entire sealing.

6

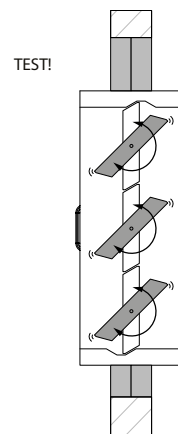

6. Check the functioning of the damper blades after the curing time of the sealing and after removing the struts. Test the mechanism of the damper.

Installation in flexible wall, sealing with rigid rock wool boards with coating

The product was tested and approved in:

Range	Wall type	Sealing	Classification
$200 \times 200 \text{ mm} \leq \text{MARKAGE FD} \leq 1000 \times 2400 \text{ mm}$	Flexible wall	Metal studs gypsum plasterboard Type F (EN 520) $\geq 100 \text{ mm}$	Stone wool + coating $\geq 140 \text{ kg/m}^3$ EI 90 ($v_e \leftrightarrow o$) S (300Pa)

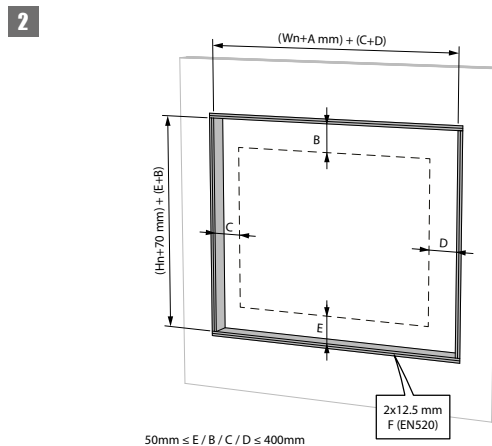
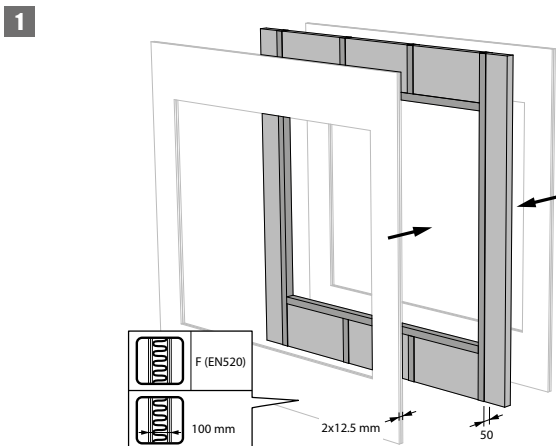

2. Make an opening with dimensions $(Wn+295+C+D) \times (Hn+70+B+E) \text{ mm}$.

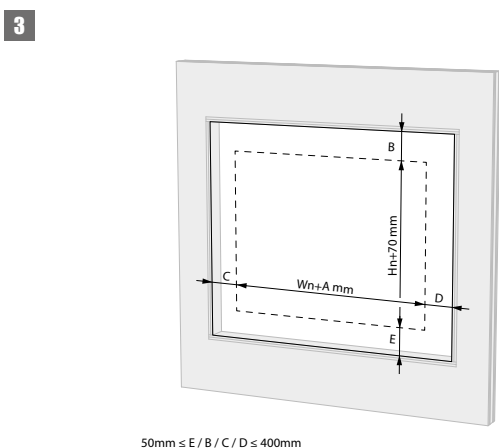

3. Mount the damper in the opening. Sealing B, C, D & E between 50 and 400 mm each. The damper does not need to be centered in the opening. The maximum distance between the damper and the edge of the opening is 400 mm.

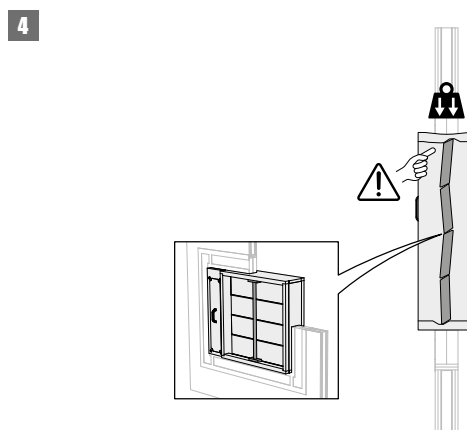

4. Support the tunnel and block the damper blades in the closed position to prevent deformation of the tunnel while the sealing is curing.

5

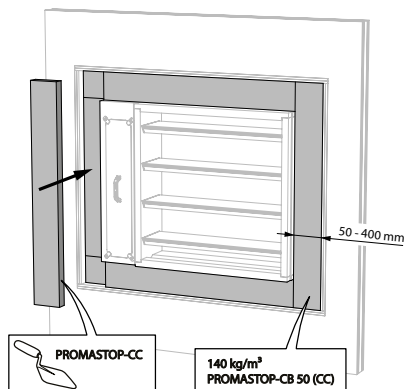

5. Seal the rest of the opening with 2 layers of 50 mm thick coated rigid mineral wool panels (type PROMASTOP CB-CC). The panels must be installed staggered. When installing, always apply coating (type PROMASTOP CC) to the end of each panel.

6

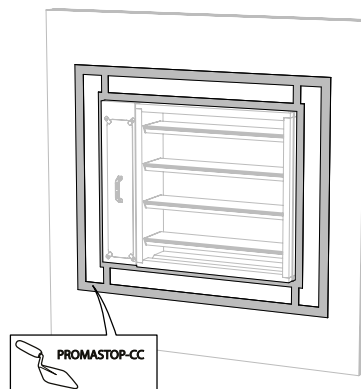

6. The panels must be installed staggered and the joints must be covered all around with coating (type PROMASTOP-CC) to create a uniform layer thickness for the entire sealing.

7

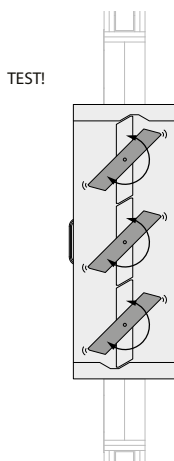

7. Check the functioning of the damper blades after the curing time of the sealing and after removing the struts. Test the mechanism of the damper.

Installation with vertical suspension (VS MAS)

1



2

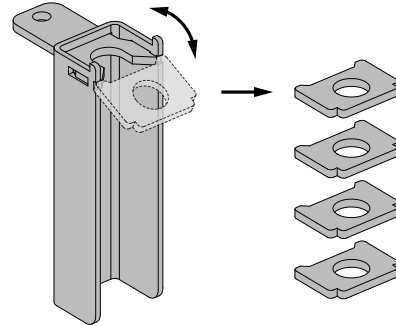

2. Break off the tabs of the angle brackets and save them for further installation.

3

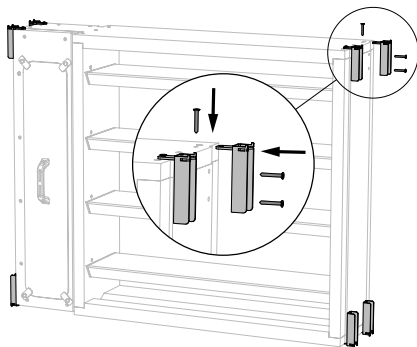

3. Fit the angle brackets on the corners of the damper. The orientation depends on the desired orientation of the damper (vertical or horizontal damper blades). Align the U-profiles of the angle brackets with one another and note the vertical direction. The short side of each angle bracket, with one screw, should be on the top or bottom of the damper.

4

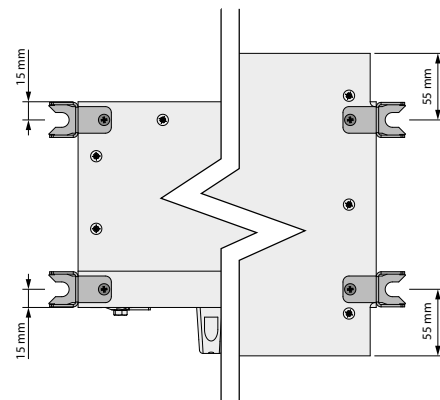

4. Attach the angle brackets with the supplied screws \varnothing 5x35 mm. The screws near the connection compartment are 15 mm from the edge, while screws in the tunnel wall are 55 mm from the edge.

5

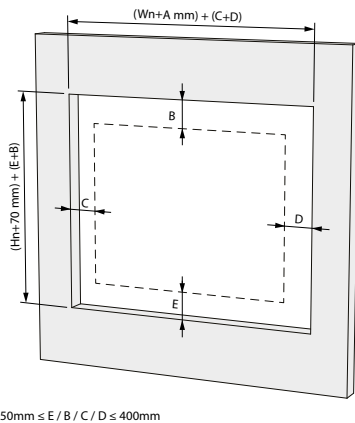

5. Position the damper in the opening of the wall according to the guidelines for each wall type.

6

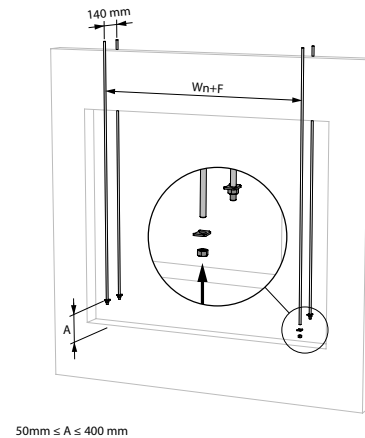

6. Fit the threaded rods ($\geq M10$) for damper suspension on the front and back of the wall, with $F = 320$ mm. Put a tab and a nut on each threaded rod. Align all tabs at the same height.

7

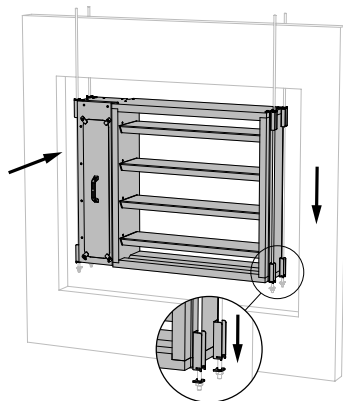

7. Place the damper on the tabs. The threaded rods must be inside the U profiles of the angle brackets. Make sure to secure the tabs to the bottom angle brackets. When passing through the compartment wall, the suspension must not be insulated. When installed in ducts, the suspension must be insulated in the same way as the suspension of the duct.

8

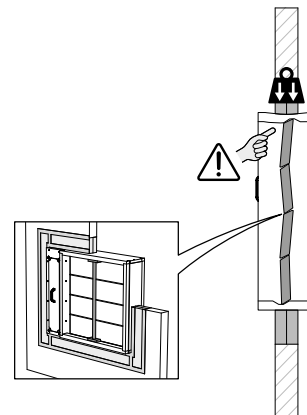

8. Support the tunnel and block the damper blades in the closed position to prevent deformation of the tunnel while the sealing is curing. Complete the sealing of the damper according to the guidelines per wall type.

Maintenance

- No specific maintenance required.
- Schedule at least 2 visual checks each year.
- Remove dust and all other particles before use.
- Follow local maintenance regulations (i.e. BS9999 Annex V; NF S 61-933) and EN13306.
- Read the maintenance instructions on our website:
https://www.rft.eu/assets/PIM/DOCUMENTS/BROCHURE%20KITS/BRO_K139_MAINTENANCE_C.pdf
- Use the damper at up to 95% humidity, non-condensing.
- The fire damper can be cleaned with a dry or slightly damp cloth. It is forbidden to use abrasive cleaners or mechanical cleaning techniques (brush).

Operation and mechanisms



BFL(T) Remotely controlled spring return actuator

The spring return actuator BFL(T) is especially designed to operate fire dampers remotely. The BFL(T) variant is intended for fire dampers with smaller dimensions (CR60, CR120, CR2 with $\varnothing \leq 400$ mm, CRS60 with $\varnothing \leq 315$ mm, CU2 / CU2-15 / CU4 with B+H ≤ 1200 mm or for CU-LT and CU-LT-1s). For Markage FD with H = 200 mm or H = 2200 mm (in combination with BFT motor).

1. locking button
2. plug (ST)
3. access for manual resetting
4. thermo-electric tripping device (T)

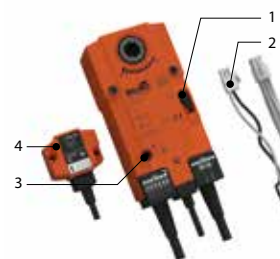

Options - at the time of order

SN2 BFL/BFN Auxiliary limit switch 'open/closed'

Unlocking

- **manual unlocking:** place the locking button on "unlock". (In case of BFLT: the damper can alternatively be unlocked by pushing the "test" button on the thermo-electric fuse)
- **automatic unlocking:** the thermo-electric fuse reacts as soon as the temperature reaches 72°C (type BFLT).
- **remote unlocking:** by interrupting the power supply.

Caution:

- ⚠ The thermo-electric fuse will not move the damper into its safety position (when the temperature reaches 72°C) if the motor is not powered.

Resetting

- **manual resetting:** turn the enclosed handle anti-clockwise. To block the motor, place the locking button on "lock"
- **motorised resetting:** switch off the power supply for at least 10 seconds. Supply the actuator (respect the prescribed voltage) for at least 75 seconds. The resetting stops automatically when the end of range is reached (damper open)
 - it takes about 60 seconds to reset the damper
 - or when the power supply is interrupted.

Caution:

- ⚠ Do not use a drill or powered screwdriver.
- ⚠ Stop as soon as the motor is completely rearmed (end of range).



BFN(T) Remotely controlled spring return actuator

The spring return actuator BFN(T) is especially designed to operate fire dampers remotely. The BFN(T) variant is intended for fire dampers with large dimensions (CRE60, CR2 with $\varnothing > 400$ mm, CRS60 with $\varnothing > 315$ mm or CU2, CU2-15, CU4 with B+H > 1200 mm. For Markage FD with H of 400 and 600 mm or with H = 1200 mm (2 pcs) and with H = 2400 mm (in combination with BFT motor).

1. locking button
2. plug (ST)
3. access for manual resetting
4. thermo-electric tripping device (T)



Options - at the time of order

SN2 BFL/BFN Auxiliary limit switch 'open/closed'

Unlocking

- **manual unlocking:** place the locking button on "unlock". (In case of BFNT: the damper can alternatively be unlocked by pushing the "test" button on the thermo-electric fuse)
- **automatic unlocking:** the thermo-electric fuse reacts as soon as the temperature reaches 72°C (type BFNT).
- **remote unlocking:** by interrupting the power supply.

Caution:

- ⚠ The thermo-electric fuse will not move the damper into its safety position (when the temperature reaches 72°C) if the motor is not powered.

Resetting

- **manual resetting:** turn the enclosed handle anti-clockwise. To block the motor, place the locking button on "lock"
- **motorised resetting:** switch off the power supply for at least 10 seconds. Supply the actuator (respect the prescribed voltage) for at least 75 seconds. The resetting stops automatically when the end of range is reached (damper open)
 - it takes about 60 seconds to reset the damper
 - or when the power supply is interrupted.

Caution:

- ⚠ Do not use a drill or powered screwdriver.
- ⚠ Stop as soon as the motor is completely rearmed (end of range).



BF(T) Remotely controlled spring return actuator

The spring return actuator B(L)F(T) is specially designed to remotely control fire dampers. The BF(T) model is intended for fire dampers with large dimensions ($\varnothing > 400$ mm or $W+H > 1200$ mm). For Markage FD with $H \geq 800$ mm and $H \leq 1600$ mm (1 piece) or with $H \geq 1800$ mm (2 pieces).

1. access for manual resetting
2. thermo-electric tripping device (T)
3. plug (ST)

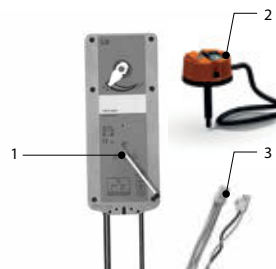

Unlocking

- **manual unlocking:** Use the enclosed handle and turn $\frac{1}{4}$ anti-clockwise.
- **automatic unlocking:** As soon as the temperature exceeds 72°C (Type BFT).
- **remote unlocking:** By interrupting the power supply.

Caution:

- ⚠ The thermo-electric fuse will not move the damper into its safety position (when the temperature reaches 72°C) if the motor is not powered.

Resetting

- **manual resetting:** Use the enclosed handle and turn anti-clockwise. To block the motor, turn back a quarter of a turn.
- **motorised resetting:** Switch off the power supply for at least 10 sec. Supply the actuator (respect the prescribed voltage) for at least 120 sec. The resetting stops automatically
 - when the end of range is reached (damper open). It takes about 75 sec. to reset the damper.
 - or when the power supply is interrupted.

Caution:

- ⚠ Do not use a drill or powered screwdriver.
- ⚠ Stop as soon as the motor is completely rearmed (end of range).

Electrical connection

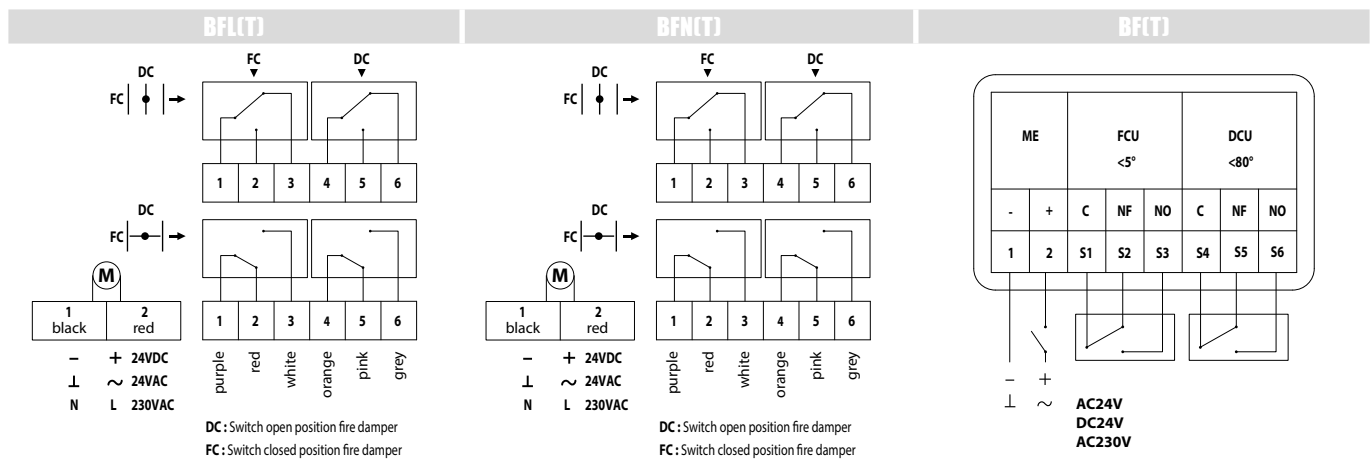

MEC	Nominal voltage motor	Nominal voltage magnet	Power consumption (stand-by)	Power consumption (operating)	Standard switches	Resetting time motor
BFLT24	24 V AC/DC	N/A	0,8 W	2,5 W	1mA...3A, AC 250V	< 60 s
BFLT230	230 V AC	N/A	1,4 W	4 W	1mA...3A, AC 250V	< 60 s
BFLT24-ST	24 V AC/DC	N/A	0,8 W	2,5 W	1mA...3A, AC 250V	< 60 s
BFNT24	24 V AC/DC	N/A	1,1 W	4 W	1mA...3A, AC 250V	< 60 s
BFNT230	230 V AC	N/A	1,8 W	5,5 W	1mA...3A, AC 250V	< 60 s
BFNT24-ST	24 V AC/DC	N/A	1,1 W	4 W	1mA...3A, AC 250V	< 60 s
BFT24	24 V AC/DC	N/A	2 W	7 W	1mA...3A, DC 5V...AC 250V	120 s
BFT230	230 V AC	N/A	3 W	8,5 W	1mA...3A, DC 5V...AC 250V	120 s
BFT24-ST	24 V AC/DC	N/A	2 W	7 W	1mA...3A, DC 5V...AC 250V	120 s

MEC	Running time spring	Noise level motor	Noise level spring	Cable supply / control	Cable auxiliary switch	Protection class
BFLT24	20 s	< 43 dB (A)	< 62 dB (A)	1 m, 2 x 0.34 mm ² (halogen-free)	1 m, 6 x 0.75 mm ² (halogen-free)	IP 54
BFLT230	20 s	< 43 dB (A)	< 62 dB (A)	1 m, 2 x 0.75 mm ² (halogen-free)	1 m, 6 x 0.75 mm ² (halogen-free)	IP 54
BFLT24-ST	20 s	< 43 dB (A)	< 62 dB (A)	1 m, 2 x 0.75 mm ² (halogen-free)	1 m, 6 x 0.75 mm ² (halogen-free)	IP 54
BFNT24	20 s	≤ 55 dB (A)	ca. 70 dB (A)	1 m, 2 x 0.34 mm ² (halogen-free)	1 m, 6 x 0.75 mm ² (halogen-free)	IP 54
BFNT230	20 s	≤ 55 dB (A)	ca. 70 dB (A)	1 m, 2 x 0.75 mm ² (halogen-free)	1 m, 6 x 0.75 mm ² (halogen-free)	IP 54
BFNT24-ST	20 s	≤ 55 dB (A)	ca. 70 dB (A)	1 m, 2 x 0.75 mm ² (halogen-free)	1 m, 6 x 0.75 mm ² (halogen-free)	IP 54
BFT24	16 s	≤ 45 dB (A)	ca. 62 dB (A)	1 m, 2 x 0.34 mm ² (halogen-free)	1 m, 6 x 0.75 mm ² (halogen-free)	IP 54
BFT230	16 s	≤ 45 dB (A)	ca. 62 dB (A)	1 m, 2 x 0.75 mm ² (halogen-free)	1 m, 6 x 0.75 mm ² (halogen-free)	IP 54
BFT24-ST	16 s	≤ 45 dB (A)	ca. 62 dB (A)	1 m, 2 x 0.75 mm ² (halogen-free)	1 m, 6 x 0.75 mm ² (halogen-free)	IP 54

Selection data

MARKAGE FD - Netto flow [m²]

Hn\Wn [mm]		200	250	300	350	400	450	500	550	600	650	700	750	800	850	900	950	1000
200	Sn [m ²]	0,0340	0,0425	0,0510	0,0595	0,0680	0,0765	0,0850	0,0935	0,1020	0,1105	0,1190	0,1275	0,1360	0,1445	0,1530	0,1615	0,1700
400	Sn [m ²]	0,0680	0,0850	0,1020	0,1190	0,1360	0,1530	0,1700	0,1870	0,2040	0,2210	0,2380	0,2550	0,2720	0,2890	0,3060	0,3230	0,3400
600	Sn [m ²]	0,1020	0,1275	0,1530	0,1785	0,2040	0,2295	0,2550	0,2805	0,3060	0,3315	0,3570	0,3825	0,4080	0,4335	0,4590	0,4845	0,5100
800	Sn [m ²]	0,1360	0,1700	0,2040	0,2380	0,2720	0,3060	0,3400	0,3740	0,4080	0,4420	0,4760	0,5100	0,5440	0,5780	0,6120	0,6460	0,6800
1000	Sn [m ²]	0,1700	0,2125	0,2550	0,2975	0,3400	0,3825	0,4250	0,4675	0,5100	0,5525	0,5950	0,6375	0,6800	0,7225	0,7650	0,8075	0,8500
1200	Sn [m ²]	0,2040	0,2550	0,3060	0,3570	0,4080	0,4590	0,5100	0,5610	0,6120	0,6630	0,7140	0,7650	0,8160	0,8670	0,9180	0,9690	1,0200
1400	Sn [m ²]	0,2380	0,2975	0,3570	0,4165	0,4760	0,5355	0,5950	0,6545	0,7140	0,7735	0,8330	0,8925	0,9520	1,0115	1,0710	1,1305	1,1900
1600	Sn [m ²]	0,2720	0,3400	0,4080	0,4760	0,5440	0,6120	0,6800	0,7480	0,8160	0,8840	0,9520	1,0200	1,0880	1,1560	1,2240	1,2920	1,3600
1800	Sn [m ²]	0,3060	0,3825	0,4590	0,5355	0,6120	0,6885	0,7650	0,8415	0,9180	0,9945	1,0710	1,1475	1,2240	1,3005	1,3770	1,4535	1,5300
2000	Sn [m ²]	0,3400	0,4250	0,5100	0,5950	0,6800	0,7650	0,8500	0,9350	1,0200	1,1050	1,1900	1,2750	1,3600	1,4450	1,5300	1,6150	1,7000
2200	Sn [m ²]	0,3740	0,4675	0,5610	0,6545	0,7480	0,8415	0,9350	1,0285	1,1220	1,2155	1,3090	1,4025	1,4960	1,5895	1,6830	1,7765	1,8700
2400	Sn [m ²]	0,4080	0,5100	0,6120	0,7140	0,8160	0,9180	1,0200	1,1220	1,2240	1,3260	1,4280	1,5300	1,6320	1,7340	1,8360	1,9380	2,0400

Sample order

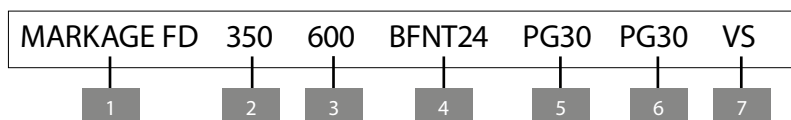

1. product
2. width
3. height
4. servomotor type
5. connection flange on the side of the access hatch
6. connection flange on the opposite side of the access hatch
7. option

Approvals and certificates

All our dampers are submitted to a number of tests by official test institutes. Reports of these tests form the basis for the approvals of our dampers.



EN 15650:2010 BCCA-0749-CPR-BC1-606-0464-15650.XX-2517